

BRONZO ECO FLOODLIGHT



LUMINAIRE SPECIFICATIONS

• Power	25W 50W 70W
• Fitting Material	Die-cast aluminium Non-corrosive
• Fitting Color	White Aluminium, Akzo Nobel RAL9006
• Optical Cover	Anti Glare High Transparency Frosted Tempered Glass
• Ingress Protection	IP65
• Impact Protection	IK08
• Voltage	220 ~ 240 Vac 50 / 60Hz
• Electrical Safety Class	Class I
• Operating Temperature	-30 ~ +40°C
• Installation	Mounting Bracket
• Surge Protections	10KV, 20KA

LED MODULE SPECIFICATIONS

• Color Temperature	3000K Warm White 5700K Day Light
• Color Rendering Index (CRI)	>70 Cool White & Neutral White >80 Warm White
• L70	50,000 Hrs @ 25°C
• PCB Material	Metal Core

FEATURES

- Direct AC supply connection (220 ~ 240 Vac 50 / 60Hz)
- No external driver required
- High system efficiency
- High performance COB

COMPLIANCE STANDARD

• LED	LM 80
• Luminaire	IEC 60529

APPLICATION

- Parking Areas, Facade Lightings, Sport Lightings, Commercial Areas, Residential Areas & Shopping Malls



MEASUREMENT & ORDER CODE

BRONZO 25W

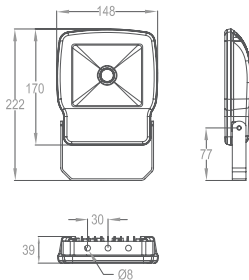

BRONZO 50W

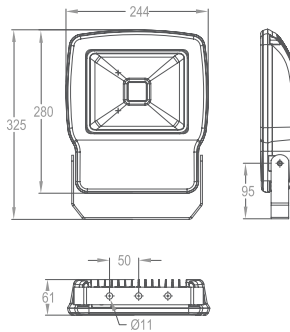

BRONZO 70W

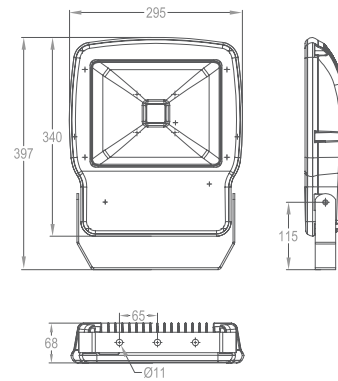

WATTAGE	ORDER CODE	CARTON DIMENSION (L x W x H) mm	NETT WEIGHT
25W	K10133 25W	225 x 153 x 42	0.6 kg
50W	K10134 50W	333 x 250 x 86	1.5 kg
70W	K10135 70W	401 x 301 x 92	2.5 kg

* Please indicate LED color temperature when ordering.

PHOTOMETRIC

BRONZO 25W

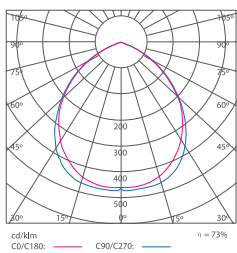

BRONZO 50W

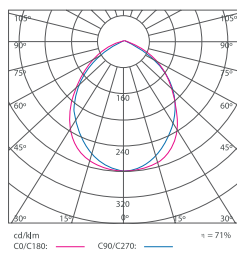

BRONZO 70W

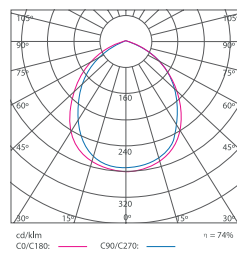

WATTAGE	NO. OF LEDS	TYPICAL LUMINOUS FLUX @ 700 mA	TYPICAL WATTAGE
25W	COB	1600	25
50W	COB	3600	50
70W	COB	5100	70

* All result tested base on 5700K CCT LEDs.